



RAPID-TORC® RTX Serie

If you can fit just with a slugging wrench, you will fit with our Low Profile RTX !

Low Clearance RTX Series...wherever you cannot fit!

THE RIGHT TOOL FOR ALL YOUR CONFINED AREAS

Key Benefits:

- 6 Models from 167 ft-lbs up to 31,000 ft-lbs
- Large Choice of Ratchet Links in 1/16" increments
- Four Mechanical moving parts (Hand-Free operations)
- One Way Ratchet System for a Single Operator "Hands Free Operation"
- Double Acting Operation
- Automatic "Ratchet Link-Piston Rod End" Attachment
- Low profile for Ratchet link and Power-Head
- Snap-in, Interchangeable Ratchet Link. No tools required.
- Very high ratio Torque to weight
- Constant maximum torque value for each model no matter the hex size
- Tight Radius Ratchet Link
- Strong Unibody Design
- Anti Side Load Resistant Link Design
- In Line Reaction Pad for maximum strength
- Robust Double Tooth Ratchet Mechanism
- Never-Lock Torque Mechanism
- Uni-Swivel Multi Axis 360° x 180°
- Housing made of Aircraft Quality Aluminum
- Output Accuracy certified at +/- 3%%
- Repeatability certified at +/- 1%
- Heavy duty finish for a Fully Corrosion resistance
- CE approved



Accessories available:

Hexagonal inserts reducers

Adapter male hex. to male square drive

Impact sockets

Large choice of reaction arms



RAPID-TORC
 BIG NUTS - BIG TOOL
 WWW.RAPIDTORC.COM



RAPID-TORC® RTX Serie

Models		RTX-2	RTX-4	RTX-8	RTX-14	RTX-30
Hex drive	Inch	3/4"-2 3/4"	1"-3 1/8"	1 5/8"-4 1/8"	2 1/2"-4 3/4"	3 1/2"-6 1/2"
	mm	19-60	25-80	46-110	60-120	90-165
Torque Min.	Ft-lbs	255	580	1143	2010	4770
	Nm	346	786	1549	2725	6466
Torque Max.	Ft-lbs	1710	3855	8151	13400	31800
	Nm	2318	5226	11049	18165	43108
L	inch	7,2	9,76	12,12	14,64	16,02
	mm	183	248	308	372	406
NS	inch	3/4"-2 9/16"	1 5/16"-3 1/8"	1 13/16"-3 7/8"	2"-4 5/8"	3 9/16"-6-1/2"
	mm	19-65	32-80	46-100	50-120	90-165
R	inch	0,35	0,47	0,59	0,72	0,87
	mm	9	12	15	18,5	22
W1	inch	1,26	1,65	2,08	2,48	3,26
	mm	32	42	53	63	83
W2	inch	1,92	2,56	3,22	3,89	5,28
	mm	49	65	82	99	132
Weight* *Average weight with one ratchet link	Lbs	4,5	9,7	19,5	33	78
	Kg	2,2	4,9	10	11,5	39

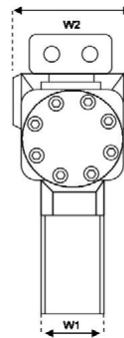
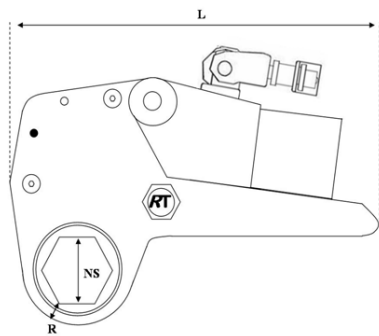

Reaction arms - accessories

